



STATE OF NORTH CAROLINA
DEPARTMENT OF TRANSPORTATION

ROY COOPER
GOVERNOR

JAMES H. TROGDON, III
SECRETARY

September 20, 2018

WBS No: 50138.3.169
Contract No: DJ00264
County: Union
Description: Grading, Drainage, Paving and Thermoplastic Pavement Markings for the Construction at US 21 and Lakeview, I-77/US 21 SB Ramp at Trade Street, Harris at Old Concord, and Westinghouse at I-77 NB

Addendum No. 1
October 3, 2018 Letting

To: Prospective Bidders

Please note the following revision to the proposal for the above referenced project.

- Special Provisions were added for the Signal Installation. Special provisions are attached.
- Signal installation pay item **INSTALL BASE MOUNTED CABINET** (Line No. 50) was added to the bid sheet. A revised bid sheet is attached.
- Signal installation pay item **CONTROLLER WITH CABINET (TYPE 2070L, BASE MOUNTED)** (Line No. 46) was removed from the bid sheet. A revised bid sheet is attached.

The changes and attachments included with this addendum will become part of contract DJ00264.

For Electronic Bid using Bid Express® please delete the EBS files you previously downloaded for DJ00264 for the October 3, 2018 letting and download the new EBS files (DJ00264.EBS and DJ00264.001) listed for DJ00264. Bid Express will not accept your bid unless the new EBS file associated with the October 3, 2018 letting is used.

If you have any questions, please contact me at (704) 983-4400.

Sincerely,

DocuSigned by:
Donald Harward
D47AFDC4A327453...

Donald Harward
Division/Design Construct Engineer

cc: Kellie Crump, Project Manager
File

Mailing Address:
NC DEPARTMENT OF TRANSPORTATION
HIGHWAY DIVISION 10
716 WEST MAIN ST.
ALBEMARLE, NC 28001

Telephone: (704) 983-4400
Fax: (704) 982-3146
Customer Service: 1-877-368-4968

Location:
716 WEST MAIN ST.
ALBEMARLE, NC 28001

Website: www.ncdot.gov

WBS : 50138.3.169 F.A. # HSIP-0077(007) TIP: W-5601FL

Type of Work: Grading, Paving, Milling, Drainage, Thermoplastic Pavement Markings, and Signals.

County: Mecklenburg

Location: Intersections at US 21 and Lakeview, I-77/US21 SB Ramp at Trade St., Harris at Old Concord, and Westinghouse at I-77 NB

LINE NO.	DESC. NO.	MASTER ITEM NO.	SEC. NO.	ITEM DESCRIPTION	EST. QTY.	UNIT	UNIT PRICE	TOTAL AMOUNT
1	1	0000100000-N	800	MOBILIZATION	1	LS		
2	33	0043000000-N	226	GRADING	1	LS		
3	35	0057000000-E	226	UNDERCUT EXCAVATION	25	CY		
4	185	1220000000-E	545	INCIDENTAL STONE BASE	50	TON		
5	196	1330000000-E	607	INCIDENTAL MILLING	910	SY		
6	202	1491000000-E	610	ASPHALT CONC BASE COURSE, TYPE B25.0C	85	TON		
7	205	1503000000-E	610	ASPHALT CONC INTERMEDIATE COURSE, TYPE I19.0C	30	TON		
8	209	1523000000-E	610	ASPHALT CONC SURFACE COURSE, TYPE S9.5C	205	TON		
9	216	1575000000-E	620	ASPHALT BINDER FOR PLANT MIX	18	TON		
10	221	1693000000-E	654	ASPHALT PLANT MIX, PAVEMENT REPAIR	20	TON		
11	372	2830000000-N	858	ADJUSTMENT OF MANHOLES	1	EA		
12	373	2845000000-N	858	ADJUSTMENT OF METER BOXES OR VALVE BOXES	1	EA		
13	595	4400000000-E	1110	WORK ZONE SIGNS (STATIONARY)	96	SF		
14	607	4430000000-N	1130	DRUMS	30	EA		
15	646	4695000000-E	1205	THERMOPLASTIC PAVEMENT MARKING LINES (8", 90 MILS)	385	LF		
16	647	4697000000-E	1205	THERMOPLASTIC PAVEMENT MARKING LINES (8", 120 MILS)	275	LF		
17	651	4710000000-E	1205	THERMOPLASTIC PAVEMENT MARKING LINES (24", 120 MILS)	345	LF		
18	653	4725000000-E	1205	THERMOPLASTIC PAVEMENT MARKING SYMBOL (90 MILS)	13	EA		
19	674	4810000000-E	1205	PAINT PAVEMENT MARKING LINES (4")	2025	LF		
20	696	4850000000-E	1205	REMOVAL OF PAVEMENT MARKING LINES (4")	200	LF		
21	701	4875000000-N	1205	REMOVAL OF PAVEMENT MARKING SYMBOLS & CHARACTERS	2	EA		
22	705	4891000000-E	1205	THERMOPLASTIC PAVEMENT MARKING LINES (4", 120 MILS) (HIGHLY REFLECTIVE MEDIA)	1430	LF		
23	705	4891000000-E	1205	THERMOPLASTIC PAVEMENT MARKING LINES (4", 90 MILS) (HIGHLY REFLECTIVE MEDIA)	950	LF		
24	706	4892000000-N	1205	THERMOPLASTIC PAVEMENT MARKINGS 24" YIELD LINE TRIANGLE (90 MILS)	15	EA		
25	985	6000000000-E	1605	TEMPORARY SILT FENCE	50	LF		
26	995	6036000000-E	1631	MATTING FOR EROSION CONTROL	100	SY		
27	1012	6071010000-E	SP	WATTLE	50	LF		
28	1016	6071020000-E	SP	POLYACRYLAMIDE (PAM)	1	LB		

29	1023	6084000000-E	1660	SEEDING & MULCHING	1	ACR		
30	1188	7048500000-E	1705	PEDESTRIAN SIGNAL HEAD (16", 1 SECTION W/COUNTDOWN)	4	EA		
31	1189	7060000000-E	1705	SIGNAL CABLE	4510	LF		
32	1194	7120000000-E	1705	VEHICLE SIGNAL HEAD (12", 3 SECTION)	25	EA		
33	1195	7132000000-E	1705	VEHICLE SIGNAL HEAD (12", 4 SECTION)	3	EA		
34	1207	7264000000-E	1710	MESSENGER CABLE (3/8")	1790	LF		
35	1211	7300000000-E	1715	UNPAVED TRENCHING (1 CONDUIT, 2 INCH)	2820	LF		
36	1216	7324000000-N	1716	JUNCTION BOX (STANDARD SIZE)	23	EA		
37	1217	7348000000-N	1716	JUNCTION BOX (OVER-SIZED, HEAVY DUTY)	7	EA		
38	1218	7360000000-N	1720	WOOD POLE	14	EA		
39	1219	7372000000-N	1721	GUY ASSEMBLY	26	EA		
40	1223	7420000000-E	1722	2" RISER WITH WEATHERHEAD	42	EA		
41	1226	7444000000-E	1725	INDUCTIVE LOOP SAWCUT	1645	LF		
42	1227	7456000000-E	1726	LEAD-IN CABLE (14-2)	5345	LF		
43	1237	7516000000-E	1730	COMMUNICATIONS CABLE (6 FIBER)	425	LF		
44	1275	7642200000-N	1743	TYPE II PEDESTAL WITH FOUNDATION	4	EA		
45	1280	7684000000-N	1750	SIGNAL CABINET FOUNDATION	4	EA		
47	1303	7980000000-N	SP	ELECTRICAL SERVICE	4	EA		
48	1303	7980000000-N	SP	ETHERNET SWITCH	4	EA		
49	1303	7980000000-N	SP	SUPPLY AND INSTALL STANDOFF BRACKETS	24	EA		
50	1303	7980000000-N	SP	INSTALL BASE MOUNTED CABINET	4	EA		
Total Bid for Project								

INSTALL BASE MOUNTED CABINET

This line item is to be installed per Section 1751 as specified in the North Carolina Standard Specifications for Roads and Structures January 2018 and made operational. The cabinet, controller, and all electronic components shall be supplied by the contractor and given to CDOT for assembly. Once assembled the contractor shall pickup and install the cabinet.

1.0 TS 2 CABINET ASSEMBLY

1.1 This specification describes the minimum acceptable requirements for a TS 2 Type 1 cabinet assembly to house a NEMA TS 2 Type 1 or 2070L solid-state full-actuated traffic signal controller. The assembly shall include the cabinet, flasher, detector card rack, bus user interfaces (BIUs) to fill all positions, detector cards to fill all positions, load switches to fill all positions, eight load switch jumpers, shelf-mount MMU, shelf-mount power supply, and six flash transfer relays.

1.2 Cabinet Design Requirements

1.2.1 The cabinet shall be constructed using sheet aluminum with a minimum thickness of 3.2 mm. The outside shall be unpainted and the inside painted gloss white. No wood, wood fiber products, or other flammable material shall be used in the cabinet. All continuous welds shall be neat and of uniform consistency.

1.2.2 The size of the cabinet shall be Size 5 (as modified in the table below) or Size 6 as defined by TS 2 of the NEMA Standard Publication TS 2 - 1992, as specified by the plans. The load bay shall be configuration 3 (12 position) or configuration 4 (16 position) as defined by TS 2 of the NEMA Standard Publication TS 2 - 1992, as specified by the plans. The vehicle detector rack shall be Configuration #1 or Configuration #2 as defined by TS 2 of the NEMA Standard Publication TS 2 – 1992.

Cabinet Options	Size of Cabinet	Backpanel Configuration – Size of Load Bay	Detector Rack Size
Option 1	Pole Mount – TS2-1 Size 5 Modified (50”H x 30”W x 17”D) (no generator transfer switch)	Type 1 Configuration # 3 12-position (1-8 vehicle, 9-12 ped) load bay with two BIU rack positions	Configuration #1 with 8-position 2-channel and one BIU rack position
Option 2	Base Mount –TS2-1 Size 5 Modified (54”H x 36”W x 17”D)	Type 1 Configuration # 3 12-position (1-8 vehicle, 9-12 ped) load bay with two BIU rack positions	Configuration #1 with 8-position 2-channel and one BIU rack position
Option 3	Base Mount – Size 6 (55”H x 44”W x 26”D)	Type 1 Configuration # 4 16-position (1-8 vehicle, 9-12 ped, 13-16 overlap) load bay with two BIU rack positions	Configuration #2 with 8-position 4-channel and two BIU rack positions

1.2.3 Vertical shelf support channels shall be provided to permit adjustment of shelf location in the field. The channels shall have a single continuous slot to allow shelves to be placed at any height within the cabinet. Channels with **fixed notches** or **holes** are **not acceptable**.

1.2.4 Each cabinet shall be equipped with an extra set of unistrut channels on either side of the front section of the cabinet to permit the purchaser to mount additional equipment as necessary.

1.2.5 Shelves shall be at least 330 mm deep and be located in the cabinet to provide a minimum 25 mm clearance between the back of the shelf and the back of the cabinet. A 38 mm minimum height drawer shall be provided in the cabinet, mounted directly beneath the bottom shelf. The drawer

shall have a hinged top cover and shall be capable of storing documents and miscellaneous equipment. This drawer shall support to 22.5 kg in weight when fully extended. The drawer shall open and close smoothly. Drawer dimensions shall make maximum use of available depth offered by the controller shelf and be a minimum of 600 mm. Drawer must not block any terminals on the back plane or prevent the ability to drop the load bay if necessary.

- 1.2.6 Two shelves shall be provided in the cabinet and shall be at minimum 305 mm apart in height. Both shelves shall be vented with slots so that air can pass through. There shall be sufficient shelf space to accommodate a controller unit 330 mm high, an MMU, one 8-position card rack and external power supply. An additional space at least 305 mm high, 325 mm wide, and 305 mm deep shall be provided. The shelves shall be placed in such a manner that sufficient ventilation is provided to the controller unit, MMU, card rack, and power supply
- 1.2.7 The cabinet shall be vented and cooled by **two** thermostatically controlled fans. The fans shall be a commercially available model with a capacity of at least 2.7 m³/min. The thermostats shall have a minimum adjustable range of 70°F to 110°F and shall be preset to turn on at 95°F.
- 1.2.8 The cabinet shall be provided with a unique serial number with date of manufacture that shall be stamped directly on the cabinet or engraved on a metal or metalized mylar plate epoxied to the cabinet. The digits shall be at least 5 mm in height and located on the upper right sidewall of the cabinet near the front.

1.3 Cabinet Door

- 1.3.1 The cabinet shall be provided with one door in front that will provide access to the cabinet. The door shall be provided with a full-length piano hinge with stainless steel pins spot welded at the top of the hinge. The hinges shall be mounted so that it is not possible to remove them from the door or cabinet without first opening the door. The bottom of the door opening shall extend at least to the bottom level of the back panel. The door and hinges shall be braced to withstand a 74 kg per vertical meter of door height load applied to the outer edge of the door standing open. There shall be no permanent deformation or impairment of any of the door or the cabinet body when the load is removed.

An additional back door shall be provided with all base-mounted cabinets. The front door specification shall apply to all back door applications with the exception of an auxiliary police door.

- 1.3.2 The cabinet door shall be fitted with a Number 2 Corbin lock and a stainless steel handle with a 16 mm (minimum) diameter shaft (or equivalent cross-sectional area for a square shaft) and a three-point latch. The lock and latch design shall be such that the handle cannot be released until the lock is released. Two keys shall be provided for each cabinet. A gasket shall be provided to act as a permanent dust and weather resistant seal at the controller cabinet door facing. The gasket material shall be of a nonabsorbent material and shall maintain its resiliency after long-term exposure to the outdoor environment. The gasket shall have a minimum thickness of 6.25 mm. The gasket shall be located in a channel provided on the cabinet or on the door(s). An “L” bracket is acceptable in lieu of this channel if the gasket is fitted snugly against the bracket to insure a uniform dust and weather resistant seal around the entire door facing. Any other method is subject to purchaser approval during inspection of an order.
- 1.3.3 A locking auxiliary police door shall be provided in the door of the cabinet to provide access to a panel that shall contain a signal shutdown switch, a signal flash switch, a manual-automatic switch, and a manual advance push-button switch on a six foot plugable/removable, retractable cord. Manual control of the controller unit from the police door shall override any external control (external logic, etc.) in effect when the Manual-Automatic switch is in the manual position. Each actuation of the manual advance push-button switch shall advance the controller to the next interval. Manual control shall not override any calls for preemption. The police door shall be gasketed to prevent entry of moisture or dust and the lock shall be provided with one brass key. Switches shall be labeled for each operation.

- 1.3.4 The intake for the vent system shall be filtered with a permanent air filter. The filter should consist of a removable metal frame, 14x20x1 inch thick with replaceable fiberglass mesh filter. The filter shall be securely mounted so that any air entering the cabinet must pass through the filter. The cabinet opening for intake of air shall be large enough to use the entire filter. The air intake and exhaust vent shall be screened to prevent entry of insects. The screen shall have opening no larger than 8.1 mm². The total free air opening of the exhaust vent shall be large enough to prevent excessive backpressure on the fan.

1.4 Wiring

- 1.4.1 All wiring within the cabinet shall be neat and routed such that opening and closing the door or raising or lowering the back panel will not twist or crimp the wiring. All wiring harnesses shall be either sheathed in nylon mesh sleeving or jacketed with PVC or polyethylene insulation. Wiring leading to the cabinet door shall be sheathed in nylon mesh sleeving or be PVC jacketed cable only. All SDLC cabling shall be Belden #7203A or engineer approved equivalent.
- 1.4.2 Size
- A. All conductors between the main power circuit breakers and the signal power bus shall be a minimum size 10 AWG stranded copper. All conductors carrying individual signal lamp current shall be a minimum size 16 AWG stranded copper. All AC service lines shall be of sufficient size to carry the maximum current of the circuit or circuits they are provided for. Minimum cabinet conductor wire size shall be 22 AWG stranded copper. All wiring and insulation shall be rated for 600 V or greater.
 - B. Conductors for AC common shall be white. Conductors for equipment grounding shall be green. All other conductors shall be a color different than the foregoing.
 - C. No P.C. boards will be allowed on the back panel of the cabinet. All wiring must be done from the BIUs to the Load Switches using standard 19-gauge wiring.
 - D. Conflict monitor wires shall be colored as to correspond with the output being monitored (example: green wire for green output, yellow wire for yellow output, and red wire for red output)
- 1.4.3 A barrier terminal block with a minimum of three compression fitting terminals designed to accept up to a #4 AWG stranded wire shall be provided for connection of the AC power lines. The block shall be rated at 50 Amperes.
- 1.4.4 All terminals shall be permanently identified in accordance with the cabinet wiring diagram using an anodized silk screening process on the aluminum panel. Where through-panel solder lugs or other suitable connectors are used, both sides of the panel shall have the terminals properly identified. Identification shall be placed as close to the terminal strip as possible.
- A. Each controller input and output function shall be distinctly identified with no obstructions, at each terminal point in the cabinet, with both a number and the function designation. The same identification must be used consistently on the cabinet wiring diagrams.
 - B. Each load switch socket shall be identified by phase number, overlap number, and pedestrian phase number as applicable. No cabinet equipment, including the load switches themselves, may obstruct these identifications.
 - C. Each flash transfer base and power relay base shall be properly identified with no possible obstructions.
 - D. Each harness within the cabinet shall be distinctly identified by function on the connector end.
 - E. The flasher socket shall be distinctly identified with no possible obstruction.

F. All other sockets needed within the cabinet to fulfill the minimum requirements of the Invitation to Bid, or attachments thereof, shall be distinctly identified.

1.4.5 The ten-pin controller unit harness (A plug Type 1) shall be long enough to reach any point 600 mm above the controller shelf. The A plug Type 1 and the SDLC cable for the controller shall come from the back of the shelf for use with 2070 controller. The A plug and SDLC cable shall be placed in such a way that the 2070 controller will be on the top shelf. The conflict monitor harness and any required auxiliary harness shall reach 600 mm from the conflict monitor shelf. The conflict monitor harness and SDLC cable shall be placed in such a way that the MMU will be on the top shelf.

1.4.6 {Intentionally left blank}

1.4.7 Copper bus bars shall be provided for both the power supply neutral (common) and chassis ground. Each bus bar must provide a minimum of ten unused terminals with 8-32 X 5/16" or larger screws. All copper bus bar screw heads shall be accessible with a screw driver. Wires shall enter the bus bars from the bottom and the screw heads shall be accessed horizontally.

Copper bus bars shall be located at the bottom of the detector panel, below the load bay, and near the barrier terminal block mentioned in section 1.4.3 for chassis ground. Tie all ground bar connections in a single loop with #6 AWG wire. Bond detector racks and any panels mounted with uni-struts to the grounding loop. Uni-struts are not acceptable as ground conductors.

Copper bus bars shall be located below the load bay for AC neutral. The AC neutral and chassis ground buses shall be tied together with a removable jumper that is a minimum #10 AWG wire.

1.4.8 A 20 Ampere and a 50 Ampere thermal type circuit breaker shall be mounted and wired in the cabinet. The 20 ampere breaker shall protect the base light, trouble light, GFCI receptacle, modem duplex receptacles, and fans. The 20 Ampere breaker shall be powered from the 50 Ampere breaker. The 50 ampere breaker shall protect the signal load circuits, controller circuits, conflict monitor, flasher, and card rack detector power supply.

1.4.9 The circuit breakers shall be equipped with solderless connectors and installed on the right side wall (facing the cabinet) or lower right hand side of the back panel inside the cabinet. The breakers shall be easily accessible. The breakers shall be positioned so that the rating markings are visible.

1.4.10 A Ground Fault Circuit Interruption (GFCI) type duplex receptacle shall be mounted and wired in the lower right side wall of the cabinet. Four additional duplex receptacles (for use with communications modems) shall be mounted and wired; two in the upper left side of the cabinet and two in the upper right. These receptacles shall be wired on the load side of the 20 Amp circuit breaker. These receptacles shall be easily accessible and unobstructed by any other components.

1.4.11 {Intentionally left blank}

1.4.12 The load side of the main circuit breaker shall be protected by a primary and secondary surge suppressor, the Atlantic Scientific Zone Defender Pro (#16700) and Atlantic Scientific Zone Guardian TS (#41003), or engineer approved equivalent.

1.4.13 {Intentionally left blank}

1.4.14 The suppresser shall be connected to the line filter as recommended by the manufacturer. Number 10 AWG or larger wire shall be used for connections to the suppressor, line filter and load switch bus.

1.4.15 An LED light(s) shall be installed in the cabinet and placed in such a way that the entire cabinet is illuminated. A door switch shall be installed in the cabinet which shall turn on the light(s) when the cabinet door is opened, and turn off when the cabinet door is closed. A metal oxide

varistor (MOV) or other such transient suppression device shall be placed across the AC power input to the light(s).

- 1.4.16 A radio frequency interference (RFI) suppresser (line filter) shall be provided and installed on the load side of the signal circuit breaker and shall be protected by the surge protector. This filter shall be rated at 50 amperes and shall provide a minimum attenuation of 50 decibels over the frequency range of 200 Kilohertz to 75 Megahertz.
- 1.4.17 Transient suppression devices shall be placed on the coil side of all relays in the cabinet. DC relay coils shall have, as a minimum, a reversed biased diode across the coil. AC relays shall have MOV's or equivalent suppression across their coils. RC networks are acceptable. One suppression device shall be supplied for each relay.
- 1.4.18 Except where soldered, all wires shall be provided with lugs or other approved terminal fittings for attachment to binding posts. Insulation parts and wire insulation shall be insulated for a minimum of 600 volts.
- 1.4.19 The outgoing traffic control signal circuits shall be of the same polarity as the line side of the power source.
- 1.4.20 Two switches shall be provided on the inside face of the cabinet door that shall be labeled Test Normal-Flash and Controller On-Off. When the Test switch is in the Flash position, call for flashing operation shall transfer the traffic signal circuits from the outputs of the load switch to the output(s) of a flasher relay. When the Test switch is in the Normal position, the call for flashing operation shall permit the controller unit to continue to run so that its normal operation can be observed. The Controller On-Off switch (located near the Test Normal-Flash switch) will cause the controller unit and any auxiliary equipment to be deactivated. The Test and Controller switches should have some type of guard to protect against accidental activation. There should be ample clearance provided between switch guard and controller face when door is closed.
- 1.4.21 {Intentionally left blank}
- 1.4.22 The cabinet shall be wired so that activation of the conflict monitor will cause the controller unit, and any auxiliary equipment, to stop timing.
- 1.4.23 Conflict and manual flash for vehicle and overlap phases shall be prewired for all red.
- 1.4.24 The cabinet shall be designed and equipped with eight transfer relay positions for the 16-position cabinet and six transfer relays for the 12-position cabinet. The purchaser should be able to change flash color using simple tools to move the wires. Wires for the flash circuit shall be color coded for each output of the corresponding channel (example: green for green output, yellow for yellow output, and red for red output). Between the back plane and load bay terminals, flash circuit wires and conflict monitor wires for each channel will be isolated by channel and not bundled or tie wrapped with any other wires. The flash circuit shall be easy to change without having to remove any components (example: load switch or transfer relay). Flash circuit shall be easily accessible and free of any obstructions.
- 1.4.25 A 75 Amp, solid-state relay shall be wired between the RFI filter output and the load switch power bus. The relay shall be controlled by the signal shutdown switch and the flash switch. The relay shall be mounted to a heat sink designed to allow maximum current flow at 74 C without damaging the relay.
- 1.4.26 All exposed AC wiring points, including the RFI filter, surge suppresser, and solid state relay shall be covered with a clear non-conductive plastic cover mounted to prevent accidental contact. Unless otherwise noted in this specification, wiring at terminal strips is exempt from this requirement.
- 1.4.27 The load switch outputs shall be brought out to posted 10-32 X 5/16" binder head screw terminals. An MOV or approved equivalent suppression device shall be installed on each load

switch output. These devices shall be located on the front side of the load bay for easy access and replacement. Field wiring for the signal heads shall be connected at this terminal strip. Compression connections are not acceptable. All terminal strips for PEDs, overlaps, and vehicle phases shall all be placed on the same plane, horizontally at the bottom of the load bay.

2.0 DETECTOR PANEL AND CARD RACK

2.1 The cabinet shall have a loop detector panel mounted on the left side of the cabinet. This panel shall provide for all connections between loops at the street and the detector cards as described in the following sections.

2.2 Detector Card Rack

2.2.1 The vehicle detector card rack for the Size 5 Modified (12-position backpanel) cabinets shall be TS 2 detector rack Configuration #1 and shall accommodate a minimum of eight 2-channel or four 4-channel TS 2 detector units, one BIU and two additional slots for rack mount optical preemption wired. Slot #1 shall be wired for 2 channel and slot #2 shall be wired for 4 channel. Both shall be labeled accordingly. The vehicle detector card rack the Size 6 (16-position backpanel) cabinet shall be TS 2 detector rack Configuration #2 and shall accommodate a minimum of eight 4-channel TS 2 detector units, two BIUs and two additional slots for rack mount optical preemption wired. Slot #1 shall be wired for 2 channel and slot #2 shall be wired for 4 channel. Both shall be labeled accordingly. Bond detector rack to the grounding loop.

2.2.2 The detector card rack shall have a rigid frame with labels and shall be fabricated from aluminum and shall have slots set in a modular fashion such that the detector card edge connectors shall plug into a PCB while sliding between top and bottom card guides for each module. Mounting flanges shall be provided and be turned outward for ease of access. The detector card rack shall be bolted to a cabinet shelf. It shall be possible to unbolt the rack using simple tools.

2.2.3 All wiring to the rack shall be labeled and neatly run to other parts of the cabinet and detector termination panel.

2.2.4 The slots shall be numbered 1 to 8, left to right when viewed from the front of the rack. A flange shall be provided on the top and the bottom of the rack to label each individual channel.

2.2.5 The detector DC supply shall be bussed to a common point and wired to the detector panel.

2.2.6 The chassis ground shall be bussed to a common point and wired to the detector panel.

2.2.7 The logic ground shall be bussed to a common point and wired to the detector panel.

2.2.8 The data address for the detector BIUs shall be according to TS 2.

2.3 Detector Panel

2.3.1 The Detector Panel shall provide all connections between the detector loops and the detector cards. All detector loop input connections shall be easily accessible and free of any obstructions.

2.3.2 The panel shall be constructed of 3.2 mm aluminum.

2.3.3 The panel shall contain a 76 mm horizontal slot in each corner to accommodate 6.3 mm mounting bolts.

2.3.4 All inputs from the loops shall be brought through posted 10-32 X 5/16" binder screw terminals or 8-32 X 5/16" binder screw terminals.

- 2.3.5 Each loop pair shall be protected by lightning surge suppresser. The suppressers must be easily accessible and mounted so that they can be replaced without removing the detector panel. Suppressers shall not obstruct terminal strips making it difficult to connect loops.
- 2.3.6 Each detector will have a test switch such that when the switch is closed, a call is placed upon that detector input. The test switch will have three positions; no effect, permanently on, and momentarily on.
- 2.3.7 The detector panel for cabinet Configurations #1, #2 and #3 (12-position) shall provide the following connection points as a minimum for sixteen (16) detectors:

<u>CONNECTION POINT</u>	<u>NO. OF CONNECTION POINTS</u>
EXTERNAL 24V POWER SUPPLY	1
LOOP INPUTS	16
LOGIC GROUND	1
SPARES	6
CHASSIS GROUND BUS	1 BUS

The detector panel for cabinet Configuration #4 (16-position) shall provide the following connection points as a minimum for thirty-two (32) detectors:

<u>CONNECTION POINT</u>	<u>NO. OF CONNECTION POINTS</u>
EXTERNAL 24V POWER SUPPLY	1
LOOP INPUTS	32
LOGIC GROUND	1
SPARES	6
CHASSIS GROUND BUS	1 BUS

- 2.3.8 A chassis ground bus bar shall be provided on the panel and connected to the cabinet by a copper ground strap. The strap shall be bonded to the grounding loop.
- 2.3.9 The cabinet shall be wired and labeled for eight (8) pedestrian pushbutton inputs. The detector panel shall have eight (8) pedestrian test pushbutton inputs labeled accordingly.
- 2.3.10 Cabinet shall have easily-replaceable pedestrian pushbutton isolator PCB that isolates all eight inputs.

2.4 DETECTOR CARDS

- 2.4.1 Detector cards for configuration #3, size 5 cabinets shall be 2 channel half width with call strength indicator, adjustable sensitivity, adjustable frequency, mode selection (short, long, pulse, off) with push button programming such as EDI LMD622H or engineer approved equivalent. Detector cards for configuration #4, size 6 cabinets shall be 2 channel half width with call strength indicator, adjustable sensitivity, adjustable frequency, mode selection (short, long, pulse, off) with push button programming such as EDI LMD624H or engineer approved equivalent.

3.0 PREEMPT PANEL

- 3.1 A preempt panel shall be provided that contains all interface circuits and wiring for preemption and communication functions. The panel shall be located on the left side of the cabinet interior. Panel shall be bonded to grounding loop.
- 3.2 Three momentary test switches, one for each preempt circuit, shall be provided on the preempt panel. The operator shall not be exposed to hazardous voltages during operation of the test switches.
- 3.3 All necessary interconnection cables, relays and mounting hardware shall be provided.

3.4 There shall be a switch on the preempt/communication panel, which shall release the local controller to operate in an isolated, full-actuated manner, when necessary for maintenance purposes. The switch positions shall be labeled "SYSTEM" and "FREE".

3.5 {Intentionally left blank}

3.6 Preempt panel shall have a 12-volt AC relay prewired for preempt input 1.

3.7 All inputs and terminals shall be labeled.

4.0 POWER SUPPLY

4.1 The power supply shall be a shelf mounted, enclosed, 24 VDC power supply in accordance to Clause 5.3.5 of the NEMA Standards Publication TS 2-1992.

4.2 One power supply cable per power supply shall be furnished and installed in each cabinet. The wires shall be terminated to bus bars, terminals on the front of the backpanel, detector panels, or connector as appropriate. The connections shall be with forked spade lugs or otherwise as needed. Each individual wire shall be cut to the length required to reach the point at which it is to be connected.

5.0 TWO CIRCUIT SOLID STATE FLASHER

5.1 The solid state, two-circuit flasher shall meet the electrical and physical characteristics described in Clause 6.3 of the NEMA Standards Publication TS 2-1992. The flasher shall be Type III (dual circuit rated at 15 Amps per circuit) unit and so constructed that each component may be readily replaced if needed.

5.2 The two-circuit flasher shall be of solid-state design with LED indicator lights for each circuit and shall contain no electro-mechanical devices.

6.0 LOAD SWITCHES

6.1 The solid-state load switches shall meet the requirements set forth in Clause 6.2 of the NEMA Standards Publication TS 2-1992, and shall be "Triple-Signal Load Switch" type. Load switches shall be PDC model SSS-86 I/O load switch with LED on front, or engineer approved equivalent.

6.2 An indicator light for each circuit shall be provided in each load switch. The indicator light shall be on when a "Low Voltage Active" input to the load switch is present as well as high voltage output.

7.0 TRANSFER RELAY

7.1 Transfer relays shall be the plug-in type with LED power indication such as Reno A&E (Part No TR-200), Struthers-Dunn (Part No. 21XBXPL) or engineered approved equivalent. The relays shall have contacts a minimum of 3/8" diameter in size and shall be rated at a minimum of 30 Amps 102/240 VAC, 20 Amps 28 VDC.

8.0 GENERATOR TRANSFER SWITCH

8.1 The base mount cabinets shall contain an internal generator plug accessible from the outside by locking auxiliary door. The auxiliary door shall be gasketed to prevent entry of moisture or dust. The switch must be equipped with a Cooper CWL530P male generator plug. During a power outage, the transfer switch will isolate the emergency circuits from the utility line allowing for efficient operation of the cabinet and generator without back feeding onto the utility. The

generator plug and transfer switch shall be mounted below the lowest shelf so as not to block usable space on shelves.

9.0 MALFUNCTION MANAGEMENT UNIT

- 9.1 The MMU shall meet the NEMA TS-2 2016 standard including the NEMA standard MMU2 requirements of TS2 2016 Flashing Yellow Arrow. Also, the MMU shall have a setup wizard, diagnostic wizard, help system, memory card, Ethernet port, SDLC communications, event log, signal sequence history log, continuous intersection and status display such as EDI MMU2-16LEip or engineer approved equivalent.

10.0 CABINET RISER

- 10.1 Each cabinet shall come with the appropriate riser as specified in the following drawings.

Specifications for CDOT 10 inch Cabinet Riser

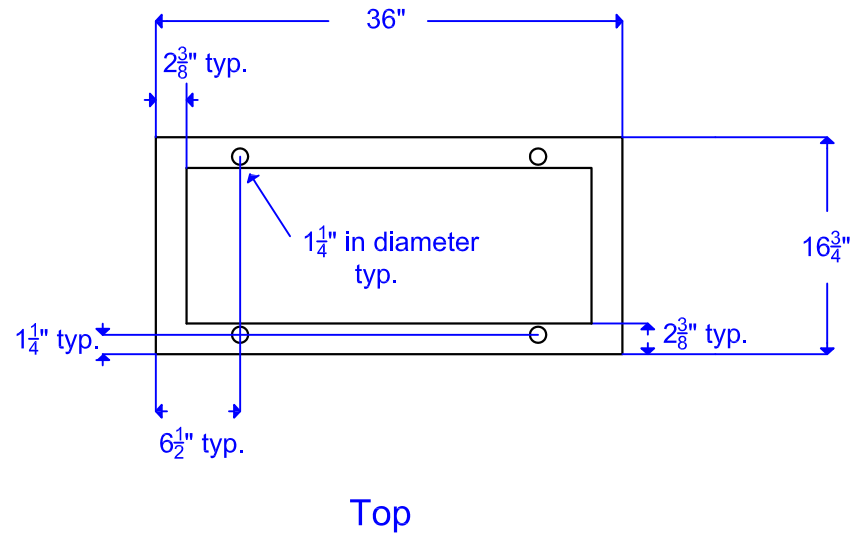
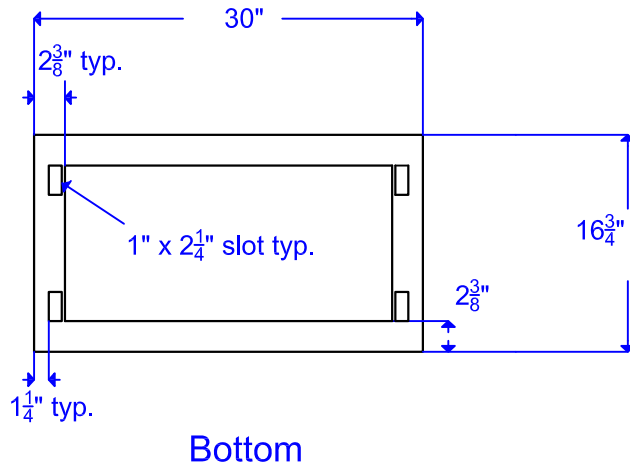
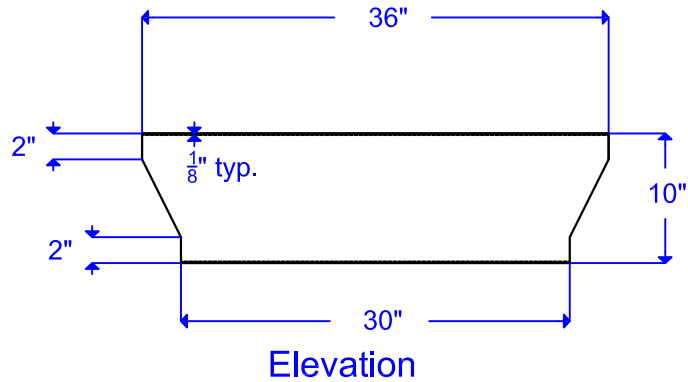

Notes:

1. Riser is to be constructed of .125" thick 5052 H-32 aluminum.
2. Riser is to be constructed using continuously welded seams.

**Charlotte Department
of Transportation**

**10 Inch Cabinet Riser
For "M" Type Cabinet
Adapter**

Date: 6/2/2014
Revision Date: 2/23/2017

Specifications for CDOT 10 inch Cabinet Riser

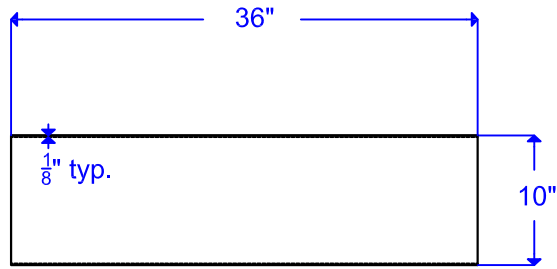

Elevation

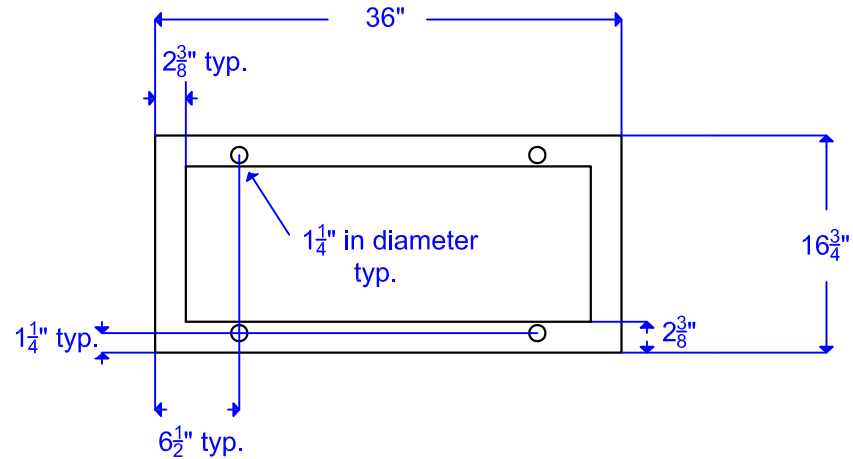

Top

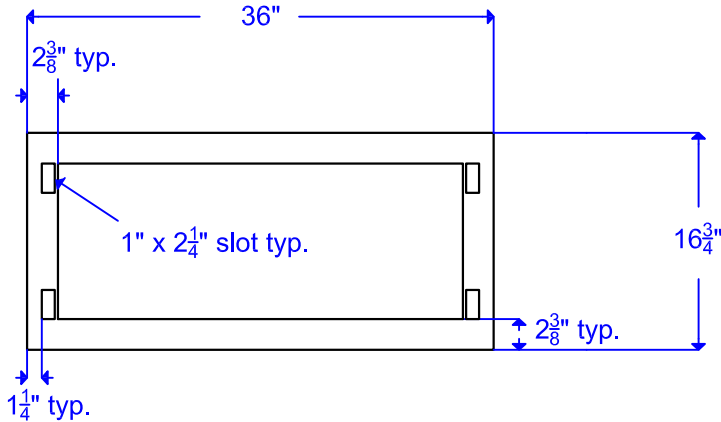

Bottom

Notes:

1. Riser is to be constructed of .125" thick 5052 H-32 aluminum.
2. Riser is to be constructed using continuously welded seams.

**Charlotte Department
of Transportation**

**10 Inch Cabinet Riser
For "M" Type Cabinet**

Date: 6/2/2014
Revision Date: 2/23/2017

Specifications for CDOT 12 inch Cabinet Riser

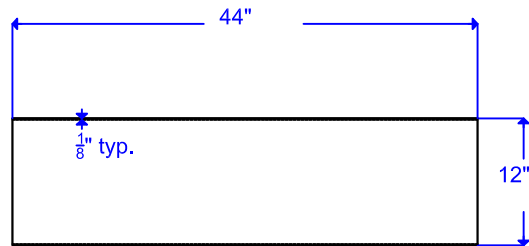

Top and Bottom Footprint

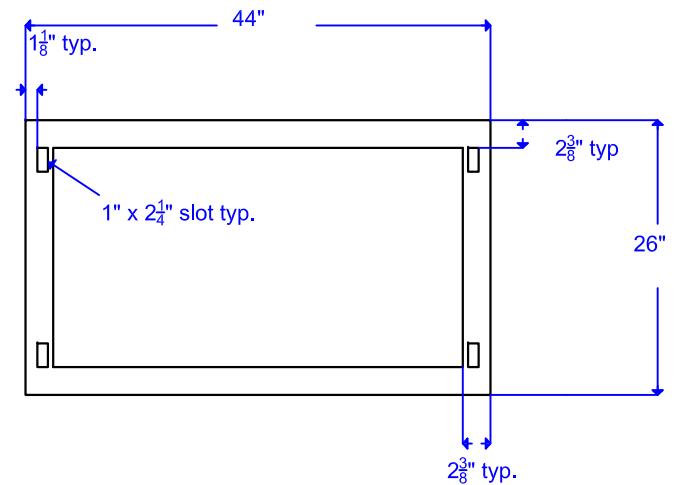

Notes:

1. Riser is to be constructed of .125" thick 5052 H-32 aluminum.
2. Riser is to be constructed using continuously welded seams.

**Charlotte Department
of Transportation**

**12 Inch Cabinet Riser
For "P" Type Cabinet
Adapter**

Date: 6/2/2014
Revision Date: 2/23/2017